

PERSYVEX Z70

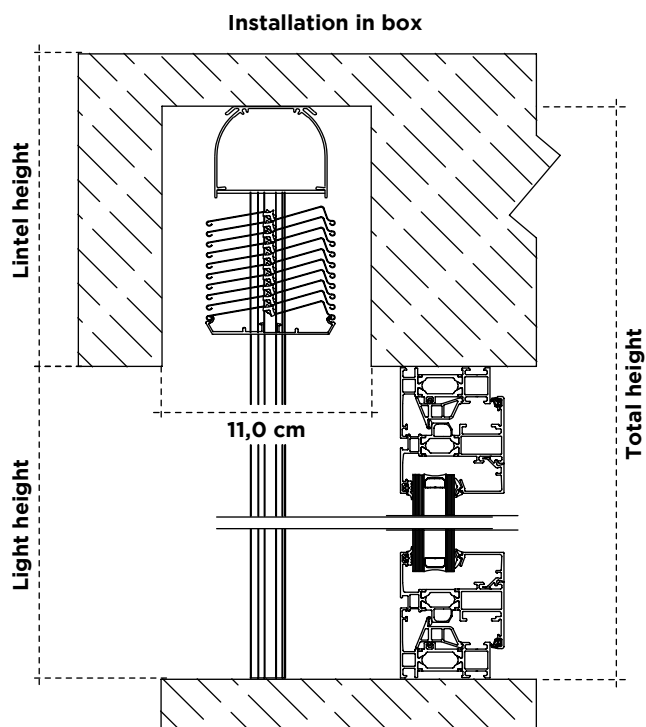

Operation	Motor
Minimum width (cm)	45
Maximum width (cm)	450
Maximum height (cm)	450
Maximum area (m²)	16
Approximate ventilation area (%)	85
Profiled aluminium. Alloy 3105H18	

* For widths of 3 metres and over, we recommend a steel cable in the centre.

	< 2,0 m	2,0 - 4,0 m	4,0 - 4,5 m
Wind resistance	6	4	3
Maximum wind speed (km/h)	88	61	49
According to standards: UNE-EN 1932:2014 UNE-EN 13659:2004+A1:2009 UNE-EN 13659:2016			

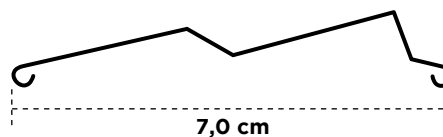

Plan

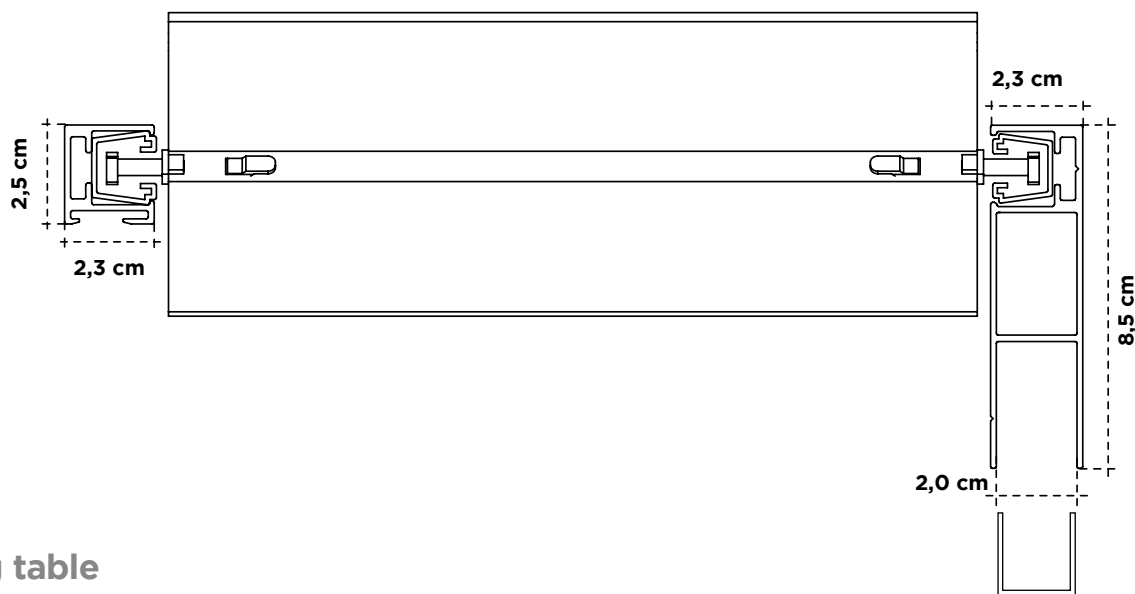

Stacking table

Total height	80	100	120	140	160	180	200	220	240	260	280	300	320	340	360	380	400	420	440	450
Tubular	18	18	19	21	21	22	23	24	25	26	27	28	29	30	32	32,5	33	35	36	37

Dimensions in cm