

PERSYVEX Z90

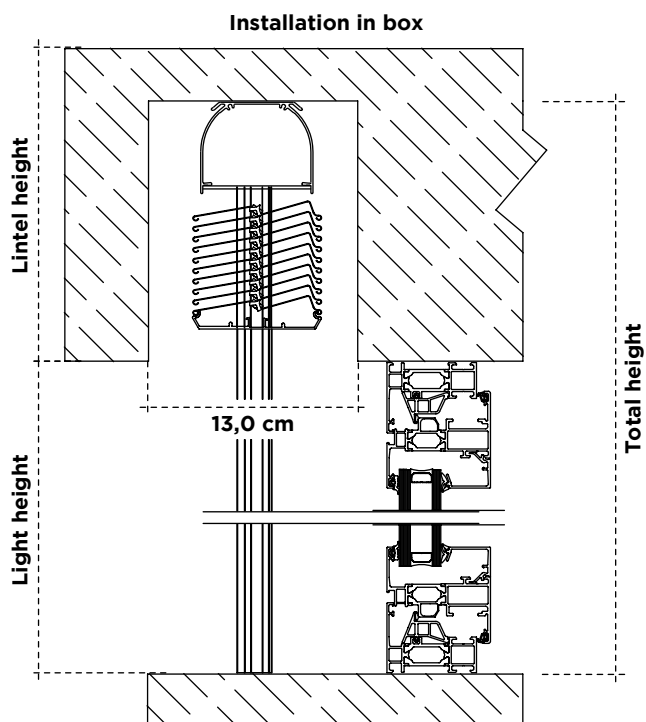

Operation	Motor
Minimum width (cm)	45
Maximum width (cm)	450
Maximum height (cm)	450
Maximum area (m²)	16
Approximate ventilation area (%)	90
Profiled aluminium. Alloy 3105H18	

* For widths of 3 metres and over, we recommend a steel cable in the centre.

	< 2,0 m	2,0 - 4,0 m	4,0 - 4,5 m
Wind resistance	6	4	3
Maximum wind speed (km/h)	88	61	49
According to standards: UNE-EN 1932:2014 UNE-EN 13659:2004+A1:2009 UNE-EN 13659:2016			



Plan

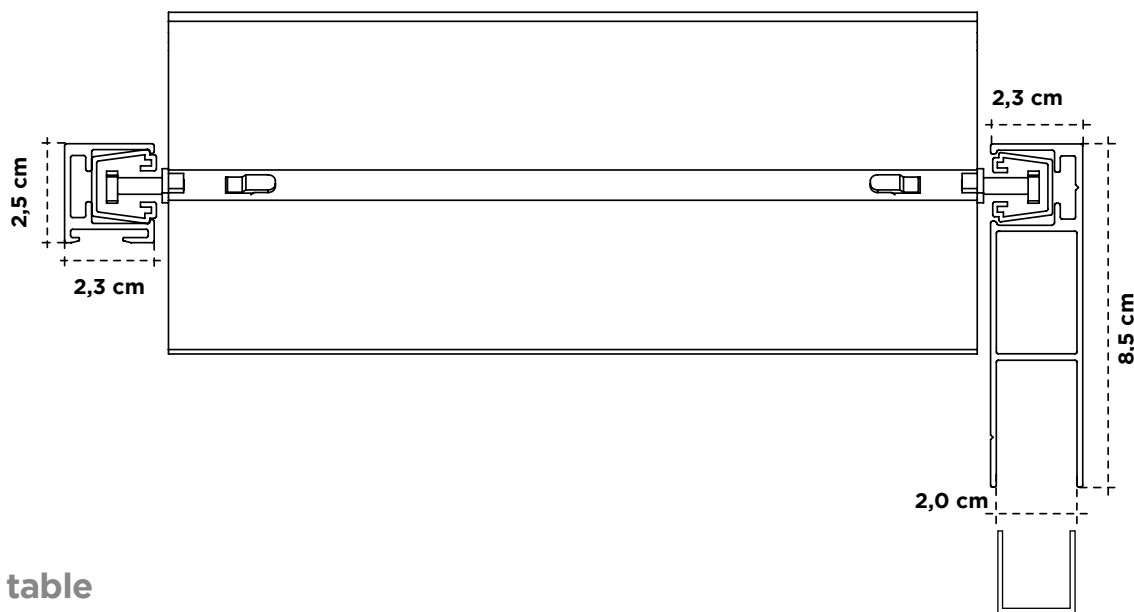

Stacking table

Total height	80	100	120	140	160	180	200	220	240	260	280	300	320	340	360	380	400	420	440	460
Tubular	16	18	18	20	20	21	21	23	23	24	24	26	26	27	27	29	29	30	30	32

Dimensions in cm